

AVERY DENNISON MARKETING SPECIFICATION

© 2019 AVERY DENNISON CORPORATION. ALL RIGHTS RESERVED

HISTORY

REV.	DATE	DESCRIPTION
A	11.20.20	RELEASED

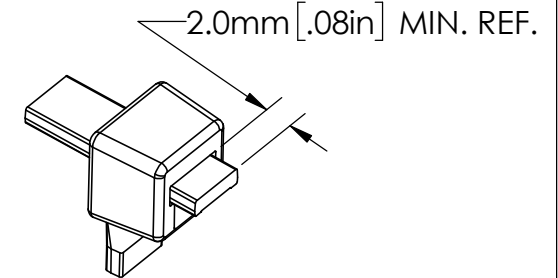
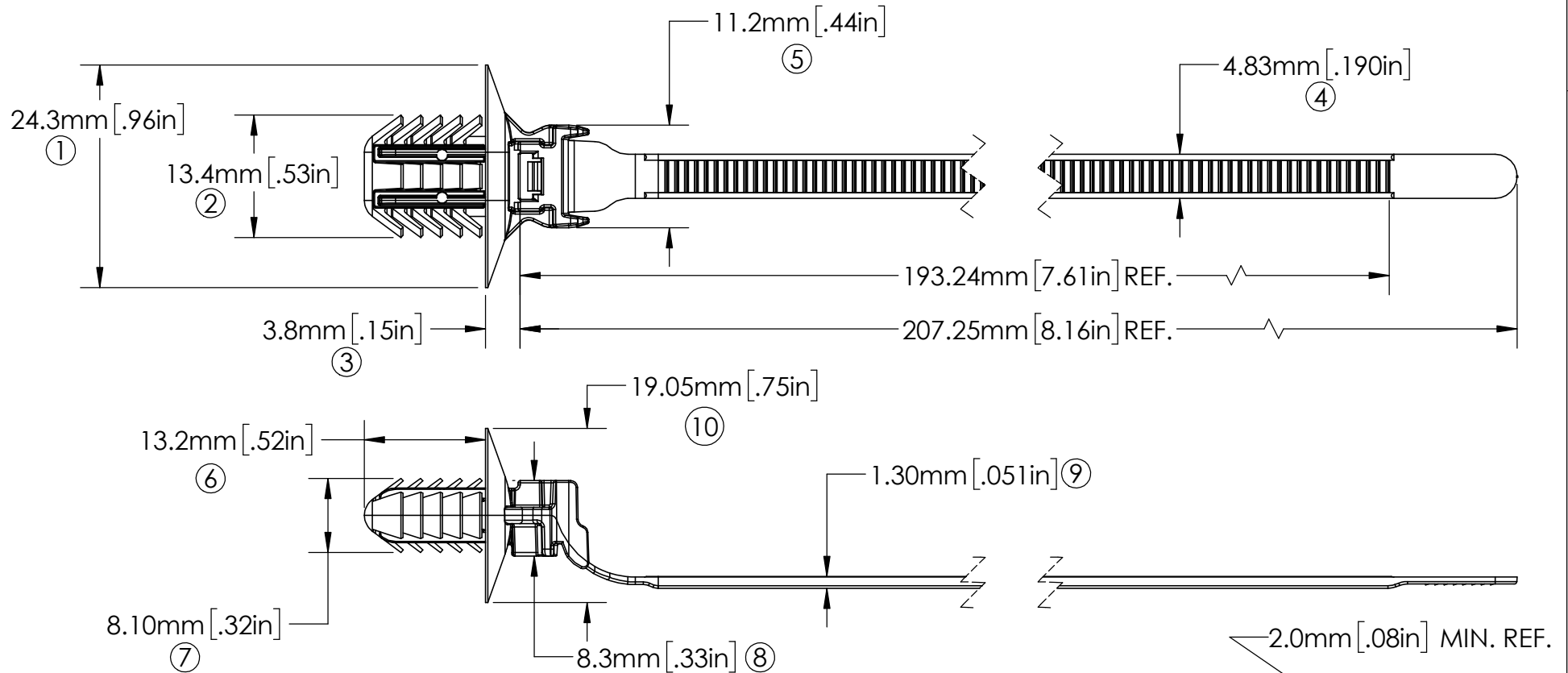

RECOMMENDED CUT LENGTH

11	△	FLAMMABILITY:	HB RATING PER FMVSS302
12	△	TENSILE STRENGTH:	50 lbf / 222N MIN.
		MOUNTING:	6.2mm X 12.2mm ; 6.5mm X 12.5mm 6.5mm X 13.0mm; 7.0mm X 12.0mm THICKNESS OF 0.6mm TO 7.0mm
		INSERTION:	10lbf / 44.5N MAX
		EXTRACTION:	25lbf per USCAR-44 NOM. FORCES: >40lbf / 178N MIN
		OPERATING TEMP RANGE:	-40 °F (-40 °C) TO 302 °F (150 °C) CONTINUOUS AND 329 °F (165 °C) AT MAXIMUM EXPOSURE
		WEIGHT:	2.3g
		BUNDLE DIAMETER:	∅ 1.6mm TO ∅ 50.0mm
		TOOL:	12001 - HAND TOOL 12500 - PNEUMATIC TOOL
		TOOL TENSION SETTING:	6 - 8
		PACKAGING:	1000/BAG, 5BAGS/MASTER

APPROVALS:	ENG. APPR.	<i>D. Gilbertson</i>	11.20.20
	Q.A. APPR.	<i>R. Estano</i>	11.20.20

SPECIFIED TOLERANCES ARE:	
.XX ± .03 INCHES	.X ± .7 mm
.XXX ± .010 INCHES	.XX ± .25 mm
ANGULAR: ± 2°	

MATERIAL	NYLON 6/6, IMPACT MODIFIED, HEAT STAB.
COLOR	BROWN

	FASTENER DIVISION FITCHBURG, MA 01420 U.S.A. TEL. 1-800-225-5913 FAX. 978-353-8157
	DESCRIPTION OVAL FIR TREE TIE, HI HEAT, 50mm MAX BUNDLE
STOCK NO.	REV.
20276-HHBN	A